

- 1.) Muffe mit Bogenrohr WW
- 2.) Muffe mit Schicht-U KW
- 3.) Muffe Zirkulation
- 4.) Flansch mit Deckel, Dichtung und Schrauben
- 5.) Muffe Fühler
- 6.) Muffe Thermometer
- 7.) Muffe Entlüftung
- 8.) Muffe Anode
- 9.) Muffe, GWT
- 10.) Muffe, GWT

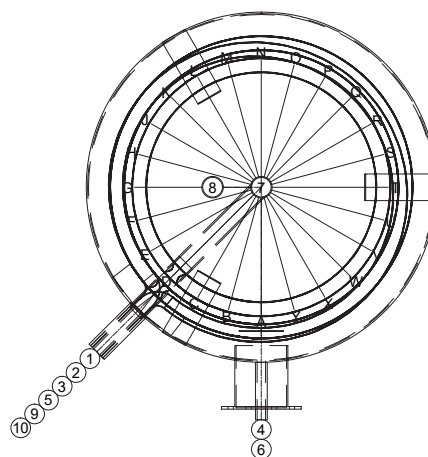

Es handelt sich um schematische Darstellungen - detaillierte Informationen entnehmen Sie bitte den folgenden Tabellen!

Isolation: - Type 300: 75 mm fix geschäumt
 - Type 650: 130 mm Polyesterfaservlies mit Polystyrol-Mantel silbergrau
 - Type 750 – 1000: 130 mm HeatBlocker-Isolation mit Polystyrol-Mantel silbergrau

Type	EWS2/300 WP		EWS2/600 WP		EWS2/750 WP		EWS2/1000 WP	
Inhalt	312l		582,0l		778,6 l		869l	
Ø roh/isoliert	-	650	-	800	790	1050	790	1050
Höhe/isoliert	-	1870	-	2020	1770	1900	2020	2150
Kippmass	1980		2170		1804		2052	
e.NLV ⁽³⁾	181		393		471		549	
GWT unten/oben	1,2 m ²	3,2 m ²	1,5 m ²	4,0 m ²	2,0 m ²	5,0 m ²	2,2 m ²	6,0 m ²
EU-WHV ⁽⁴⁾	64,9 W B		85,0 W		111,2 W		104,4 W	
Gewicht	142 kg		205 kg		259 kg		278 kg	
Anschlusshöhen und -dimensionen								
A	67	1"	175	1¼"	220	1¼"	220	1¼"
B	220	1"	320	1"	320	1¼"	320	1"
C	380	Ø 180	425	Ø 180	430	Ø 180	430	Ø 180
D	380	½"	530	½"	450	½"	450	½"
E	760	1"	770	1"	700	1¼"	820	1"
F	850	Ø 180	860	Ø 180	800	Ø 180	900	Ø 180
G	930	1¼"	950	1¼"	880	1¼"	955	1¼"
H	1170	½"	1160	½"	1050	½"	1200	½"
I	1070	¾"	1290	1"	1150	1"	1495	1"
J	1570	1¼"	1550	1¼"	1480	1¼"	1635	1¼"
K	1723	1"	1680	1¼"	1590	1¼"	1735	1¼"
L	1570	½"	1680	½"	1480	½"	1735	½"
M	1770	1¼"	1920	1¼"	1770	1¼"	2020	1¼"
N	-	-	-	-	1770	1¼"	2020	1¼"

⁽¹⁾ elektrisches Nachladevolumen

⁽²⁾⁽³⁾ Warmhalteverlust in W/h (EU) bzw. Wärmeverlust in kWh/24h (CH)

B Energieeffizienzklasse

Leistungsdaten Glattrohrwärmetauscher

Speicher	Register Heizfläche m ²	Kessel		Heizwasser		WW-Leistung TWW = 45 °C			Heizwasser		WW-Leistungen TWW = 60 °C		
		Vorlauf	Rücklauf	primär	Δ p	Spitzenleistung	Dauerleistung TKW = 10 °C		primär	Δ p	Spitzenleistung	Dauerleistung TKW = 10 °C	
		°C	°C	m ³ /h	kPa		l/10 min*	l/h				kW	m ³ /h
EWS 2/300 WP	3,2 doppelt gewendelt oben	50	40	1,72	1	103	491	20	-	-	-	-	-
		60	50	4,47	5,4		1278	52	-	-	-	-	-
		70	60	6,88	10,7		1965	80	4,82	6	103	963	56
		80	70	9,63	19,7		2752	112	8,77	19,8	103	1754	102
	1,2 unten	50	40	0,6	0,4	255	172	7	-	-	-	-	-
		60	50	1,55	2,1		442	18	-	-	-	-	-
		70	60	2,67	5,4		762	31	1,72	2,5	255	344	20
		80	70	3,96	10,7		1130	46	3,01	6,5	255	602	35
EWS 2/600 WP	4,0 doppelt gewendelt oben	50	40	2,32	2,2	218	664	27	-	-	-	-	-
		60	50	5,76	10,7		1647	67	-	-	-	-	-
		70	60	8,6	19,5		2457	100	6,19	11,9	218	1238	72
		80	70	9,89	19,8		2825	115	9,03	19,7	218	1806	105
	1,5 unten	50	40	0,8	0,8	423	221	9	-	-	-	-	-
		60	50	2,06	4,4		590	24	-	-	-	-	-
		70	60	3,44	10,6		983	40	2,24	4,9	423	447	26
		80	70	4,9	19,3		1400	57	3,87	12,9	423	774	45
EWS 2/750 WP	5,0 doppelt gewendelt oben	50	40	3,1	4,6	287	885	36	-	-	-	-	-
		60	50	7,22	19,9		2064	84	-	-	-	-	-
		70	60	8,6	19,6		2457	100	7,4	19,3	287	1479	86
		80	70	9,63	19,7		2752	112	8,77	19,8	287	1754	102
	2,0 unten	50	40	1,12	2	577	319	13	-	-	-	-	-
		60	50	2,84	10,3		810	33	-	-	-	-	-
		70	60	4,3	19,6		1229	50	3,01	11	577	602	35
		80	70	4,9	19,3		1400	57	4,47	19,2	577	895	52
EWS 2/1000 WP	6,0 doppelt gewendelt oben	50	40	3,78	7,8	336	1081	44	-	-	-	-	-
		60	50	7,22	19,9		2064	84	-	-	-	-	-
		70	60	8,6	19,6		2457	100	7,4	19,3	336	1479	86
		80	70	9,63	19,7		2752	112	8,77	19,8	336	1754	102
	2,2 unten	50	40	1,29	2,8	698	368	15	-	-	-	-	-
		60	50	3,18	14		909	37	-	-	-	-	-
		70	60	4,3	19,5		1229	50	3,44	15,8	698	688	40
		80	70	4,82	18,3		1376	56	4,47	19,2	698	894	52

*berechnet auf den oberen Fühler